

adaptall

INTERNATIONAL ADAPTER & FITTING SOLUTIONS



2015

24° DIN (BITE-TYPE) TUBE FITTINGS

24° DIN (BITE-TYPE) TUBE FITTINGS

COMPONENT COMPATIBILITY CHART

PRESSURE SERIES	TUBE O.D.	METRIC THREAD CALLOUT	WORKING PRESSURE (BAR)*	TUBE NUT PART #	CUTTING RING PART #	TUBE PLUG PART #	TUBE CAP PART #
LL	4 mm	8 mm x 1.0	100	5201LL-04	5202LL-04	-	-
	6 mm	10 mm x 1.0	100	5201LL-06	5202LL-06	-	-
	8 mm	12 mm x 1.0	100	5201LL-08	5202LL-08	-	-
	10 mm	14 mm x 1.0	100	5201LL-10	5202LL-10	-	-
	12 mm	16 mm x 1.0	100	5201LL-12	5202LL-12	-	-
L	6 mm	12 mm x 1.5	315	5201L-06	5202-06	5203L-06	5204L-06
	8 mm	14 mm x 1.5	315	5201L-08	5202-08	5203L-08	5204L-08
	10 mm	16 mm x 1.5	315	5201L-10	5202-10	5203L-10	5204L-10
	12 mm	18 mm x 1.5	315	5201L-12	5202-12	5203L-12	5204L-12
	15 mm	22 mm x 1.5	315	5201L-15	5202-15	5203L-15	5204L-15
	18 mm	26 mm x 1.5	315	5201L-18	5202-18	5203L-18	5204L-18
	22 mm	30 mm x 2.0	160	5201L-22	5202-22	5203L-22	5204L-22
	28 mm	36 mm x 2.0	160	5201L-28	5202-28	5203L-28	5204L-28
	35 mm	45 mm x 2.0	160	5201L-35	5202-35	5203L-35	5204L-35
42 mm	52 mm x 2.0	160	5201L-42	5202-42	5203L-42	5204L-42	
S	6 mm	14 mm x 1.5	630	5201S-06	5202-06	5203S-06	5204S-06
	8 mm	16 mm x 1.5	630	5201S-08	5202-08	5203S-08	5204S-08
	10 mm	18 mm x 1.5	630	5201S-10	5202-10	5203S-10	5204S-10
	12 mm	20 mm x 1.5	630	5201S-12	5202-12	5203S-12	5204S-12
	14 mm	22 mm x 1.5	630	5201S-14	5202-14	5203S-14	5204S-14
	16 mm	24 mm x 1.5	400	5201S-16	5202-16	5203S-16	5204S-16
	20 mm	30 mm x 2.0	400	5201S-20	5202-20	5203S-20	5204S-20
	25 mm	36 mm x 2.0	400	5201S-25	5202-25	5203S-25	5204S-25
	30 mm	42 mm x 2.0	400	5201S-30	5202-30	5203S-30	5204S-30
	38 mm	52 mm x 2.0	315	5201S-38	5202-38	5203S-38	5204S-38

*1 BAR = 14.7 psi

TORQUE SPECIFICATIONS CHARTS - SWIVELS

	TUBE SIZE	METRIC THREAD CALLOUT	MAX (N/m) SOFT SEAL SWIVEL NUT
	L SERIES (LIGHT DUTY)	6	12 mm x 1.5
8		14 mm x 1.5	20
10		16 mm x 1.5	32
12		18 mm x 1.5	35
15		22 mm x 1.5	68
18		26 mm x 1.5	85
22		30 mm x 2.0	120
28		36 mm x 2.0	160
35		45 mm x 2.0	215
42		52 mm x 2.0	260

	TUBE SIZE	METRIC THREAD CALLOUT	MAX (N/m) SOFT SEAL SWIVEL NUT
	S SERIES (HEAVY DUTY)	6	14 mm x 1.5
8		16 mm x 1.5	32
10		18 mm x 1.5	35
12		20 mm x 1.5	60
14		22 mm x 1.5	70
16		24 mm x 1.5	85
20		30 mm x 2.0	125
25		36 mm x 2.0	165
30		42 mm x 2.0	215
38		52 mm x 2.0	280

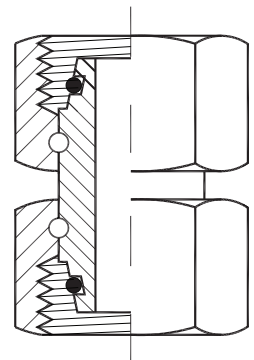

Important: Do not use torque settings to install tube assembly with cutting ring! See page 4 for assembly instructions.

24° TUBE FITTINGS

24° tube fittings, or 'Bite-Type,' are the most popular fitting globally and employ the most advanced tube fitting system in the world. This system is capable of withstanding high pressures and extreme vibration, thanks to the cutting ring design. The cutting ring is a ferrule that incorporates sharp cutting edges. When a nut is torqued onto the fitting, the base of the nut comes into contact with the cutting ring, wedging it into the 24° tapered throat of the fitting thereby cutting into and gripping the tube. Identify with caution, DIN fittings employ Metric threads and closely resemble other Metric fittings.

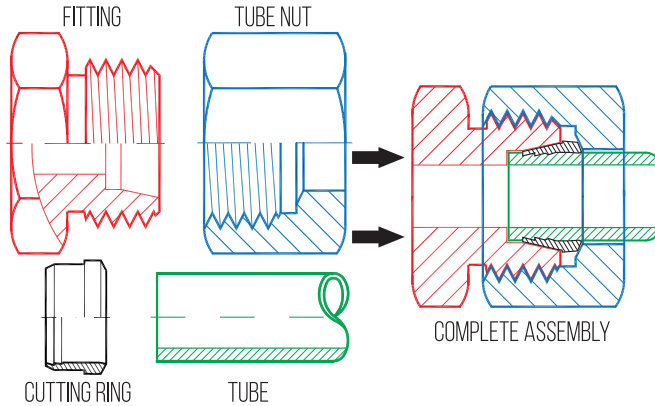

24° THROAT ANGLE

The fitting itself incorporates a 24° tapered throat adjacent to the tube receptacle (where the tube 'bottoms out'), which guides the wedging of the cutting ring while the nut provides torque. Proper attention must be given to the relevant installation instructions in order to achieve a properly sealed assembly. Refer to the 'Assembly Instructions' section for details.

STYLES AND VARIATIONS

There are numerous variations of cutting rings available, as well as mating styles incorporating swivel nuts, tube nipples and/or hose ends that replace the cutting ring in order to provide a seal. The latter versions do not require assembly by means of torquing the tube nut as the flare is already incorporated into the tube or hose. However, the 24° fitting and nut remain consistent throughout the varying styles.

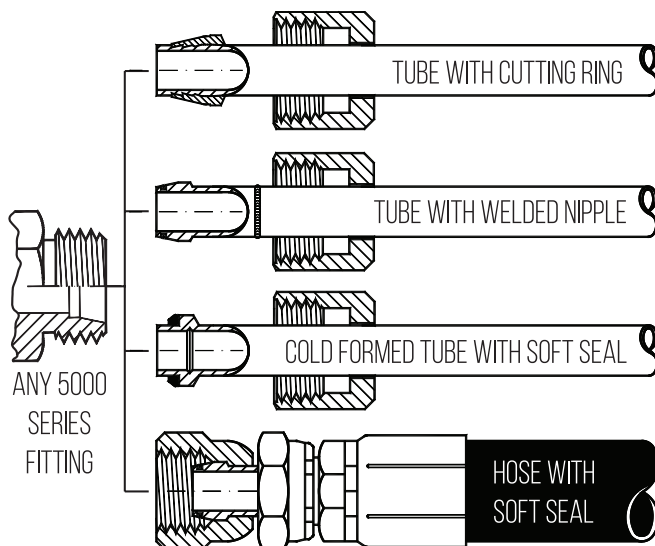

PRESSURE CLASSES

This tube fitting system is commonly referred to as Bite-Type, DIN 2353, or ISO 8434-1. The 24° fitting, nut, and cutting ring comes in three different classes: LL for low pressure applications, L for medium pressure applications, and S for high pressure applications. For working pressures and compatible components, please refer to the 'Component Compatibility Chart' on page 2.

HOW TO IDENTIFY 24° METRIC TUBE FITTINGS

The first step is to look for a size and series listed on the nut itself. It should list something like LL-08, 18-L, S20 or similar. Once identified, refer to the 'Component Compatibility Chart' for information on relevant components such as cutting rings, plugs, and caps. Not all manufacturers list this information on the nut, so further steps might be required.

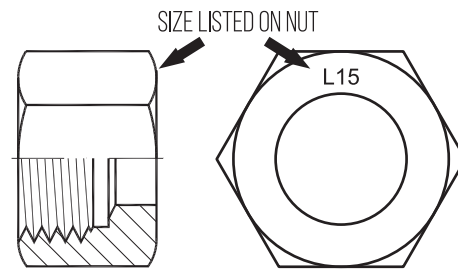

DETERMINING SIZE & SERIES MANUALLY

If no sizing information is available on the nut, the next step is to take a caliper reading of the outer diameter (O.D) of the tube or the inner diameter (I.D) of the tube receptacle inside the fitting. Be sure to set your calipers to millimeters (mm) as this is the unit of measurement all Metric tube fittings and the subsequent dash size system is based on. Note this measurement for later use.

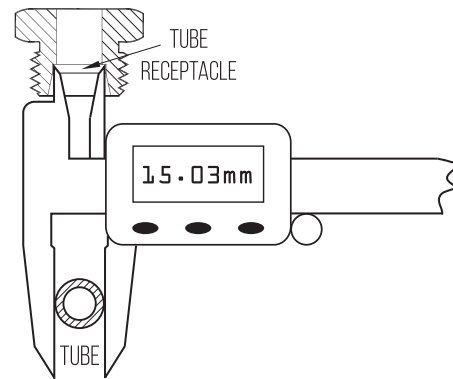

The next step is to identify the thread size and pitch. To identify thread size on a metric thread, simply take a caliper reading of the outer diameter (O.D) of the threads. With metric threads, the O.D reading directly translates to thread size (i.e. an outer diameter reading of 22.05mm equates to a 22mm thread). To identify the thread pitch, there are two options: **a)** use a caliper to measure the distance between thread crests (in mm), or **b)** use a thread pitch gauge, which is recommended in order to avoid false identification. Thread pitches in the 24° DIN tube fitting class are 1.0mm, 1.5mm, or 2.0mm. The thread size and pitch are then combined to form the 'thread callout', which could be displayed as M22x1.5 or 22mm x 1.5, etc.

24° DIN (BITE-TYPE) TUBE FITTINGS

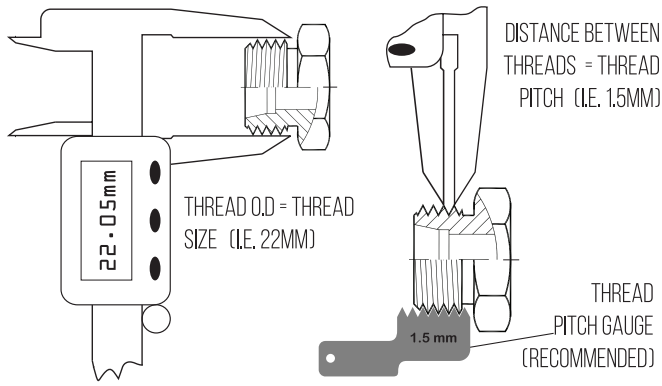

FITTING & COMPONENT COMPATIBILITY

Lastly, compare the readings with the cross reference chart on page 2 in order to verify the size and series. For example, the thread O.D is 22mm, the thread pitch is 1.5mm, while the tube size measured is 15mm. Looking at the chart, a 15mm tube size with corresponding thread callout of M22x1.5 would indicate this assembly belongs to the L series for medium pressure, or more specifically as L15. From this chart one will find part numbers for compatible components such as tube nuts, cutting rings, as well as tube plugs and caps. Be sure to verify tube size as some thread sizes overlap between the pressure series i.e. an M14x1.5 thread could belong to the L or S series.

THREAD GAUGE KIT **NEW!**

Adaptall provides a user friendly tool to aid in the identification process called the 'International Fitting Identification Kit' (part # TGK-01). It is a durable low cost tool for use in the field in order to identify Metric thread size and pitch, as well as verify 24° chamfer/throat angle. There is also a British fitting identification tool that comes in this two piece kit, made in house and unique to Adaptall. The kit is also a great counter sales item, ask about our custom branding options today.

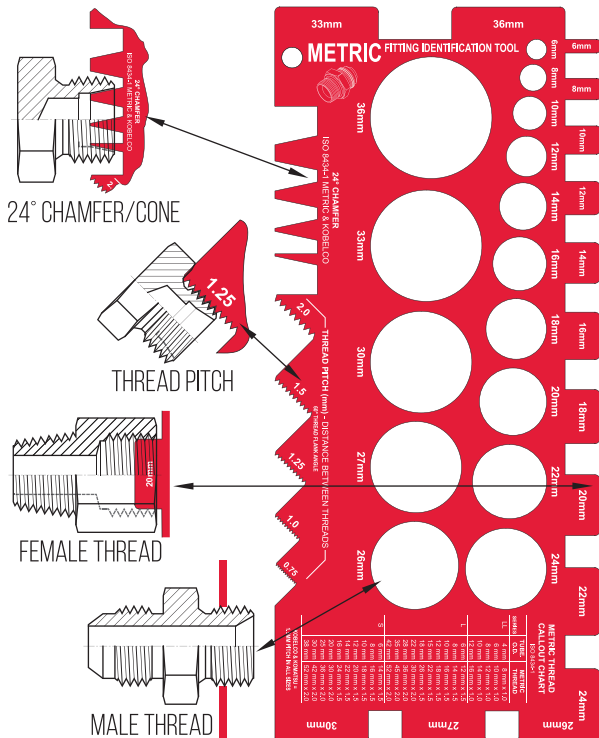

HOW TO ASSEMBLE 24° DIN TUBE FITTINGS

- 1) The first step in assembly is to cut the tube to length, then de-burr and clean. Cut tubing with appropriate saw only.
- 2) Next, pre-set the cutting ring by initiating the bite into the tube. There are two ways to complete the pre-set: either **a)** manually with a fitting or hardened pre-assembly fitting body, or **b)** with a hydraulic pre-set machine. Hydraulic pre-setting is recommended for assemblies with tube size greater than 18mm.
- 3) Perform pre-set inspection to verify proper installation of cutting ring.
- 4) Install the assembly.

MANUAL PRE-SET METHOD

To manually pre-set the cutting ring you will need either the fitting or a hardened pre-assembly fitting body. Hardened pre-assembly bodies are recommended for higher volume jobs, or when using Stainless Steel tube or standpipe fittings. Ask Adaptall for details.

- 1) Lubricate threads of fitting and nut, 24° throat, and cutting ring.
- 2) Place nut then cutting ring over tube, ensuring proper orientation.

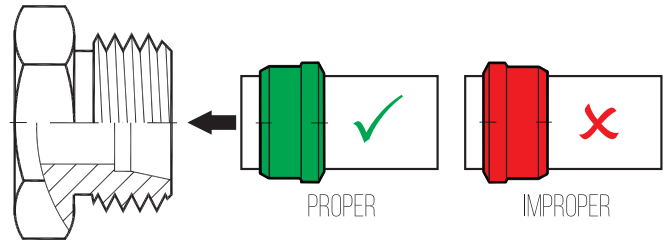

- 3) Thread nut onto fitting until finger tight. Press tube firmly into the tube receptacle of the fitting while doing so.
- 4) Mark nut and tube position for reference with soap stone or marking pencil.
- 5) Tighten nut so that it completes 1.5 turns (use markings as reference), while at the same time ensuring the tube is stationary and pressed firmly into the tube receptacle. Sudden resistance to torquing is a sign the cutting ring is in a desired position. Be sure to secure fitting with wrench while tightening the nut.

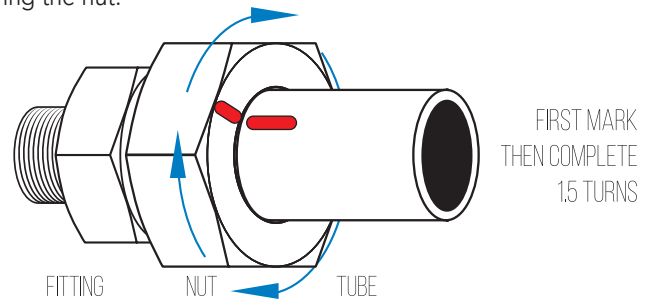

HYDRAULIC PRE-SET METHOD

There are various hydraulic pre-set machines available with specific instructions for each. Please refer to your user's manual for operating instructions.

24° DIN (BITE-TYPE) TUBE FITTINGS

PRE-SET INSPECTION

Remove the nut from fitting and pull back in order to inspect the cutting ring. The cutting ring should leave no visible gap between the first cutting surface and the tube, and the tube should have a visible bite edge in front of the cutting ring (looks like slightly raised material). If not, tighten in small increments (checking the result after each increment) to verify cutting ring is properly gripping the tube. It is possible for the ring to rotate around the tube, however this does not indicate an improper installation as long as all other factors are correct.

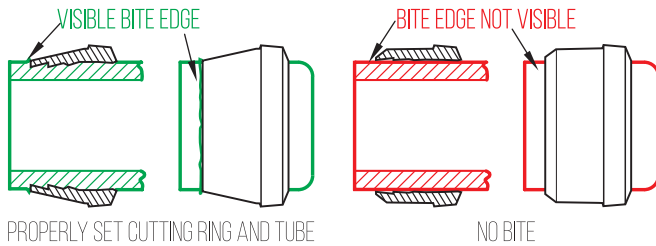

PROPERLY SET CUTTING RING AND TUBE

NO BITE

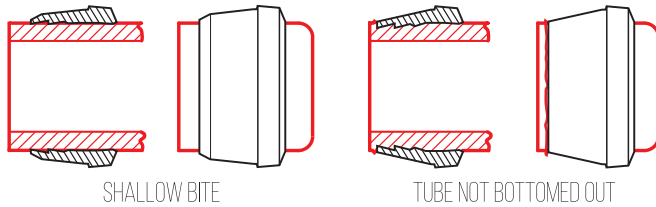

SHALLOW BITE

TUBE NOT BOTTOMED OUT

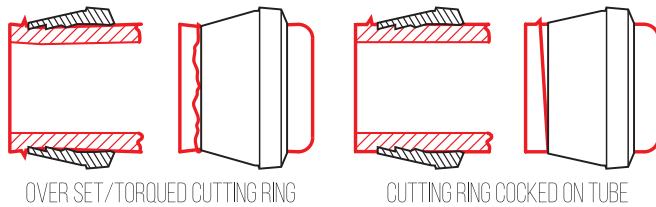

OVER SET/TORQUED CUTTING RING

CUTTING RING COCKED ON TUBE

FINAL INSTALLATION

Take the pre-set assembly and insert tube into the fitting's tube receptacle firmly, then tighten nut with light wrenching until resistance felt. Once this has been achieved, tighten the nut another 30° or 1/12th of a turn. This is the equivalent of turning the nut from a state where the hex is flat relative to a fixed point (i.e. a table) to where the sharp edge of the hex is now facing that position. Be sure to use a second wrench to hold the fitting in place while torquing the nut.

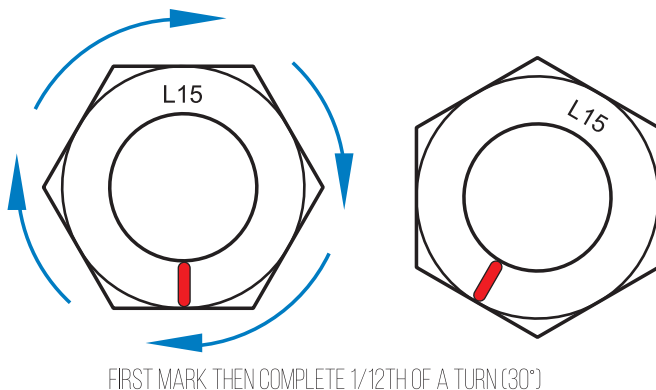

HOW TO ORDER 24° DIN TUBE FITTINGS FROM ADAPTALL

To order 24° DIN tube fittings from Adaptall it is important to understand the part number system. This system is typical of most manufacturers:

- 1) The first four numbers indicates the part series i.e. 5000 is a male DIN union. The desired series number can be determined by using the 'Visual Reference Guide' on pages 6-7, or the index on page 19.
- 2) The pressure class (LL, L, or S) is indicated at the end of the series number i.e 5000L, 5002S, 5063LL, etc.
- 3) For instances where a DIN x DIN fitting does not have a jump size, only one dash size is displayed. For example, a 5000L-06 is a light duty L06 x L06 DIN union.
- 4) The dash numbers indicate tube size when describing the DIN side of the fitting. From the last example, a 5000L-06 is an L06 indicating a M12x1.5 thread with 6mm tube receptacle; see 'Component Compatibility Chart' on page 2 for details on tube size & thread size relationship.
- 5) For non-DIN threads such as NPT, BSPP, etc., the regular dash system is used i.e. -08 indicates 1/2", -12 is 3/4", etc. Adaptall usually displays dash sizes with tube or hose side first, then port side.
- 6) To order a complete DIN assembly (including fitting, cutting ring, and nut) simply add a "C" to the end of the part number. For example, a complete L06 male DIN union assembly would be 5000L-06C, etc. Please note that all LL series (extra light duty) parts come complete.

When a complete assembly is ordered from Adaptall, there is no need to identify components to go along with your assembly. Adaptall will complete the necessary steps to ensure you are provided with compatible components.

Example:

Shown below in black only is 5158L-22-22-12: Male DIN X Male BSPP adjustable Run Tee, size L22 for the DIN threads, and dash size 12 BSPP (3/4"). When ordered as part number 5158L-22-22-12C it comes as a complete assembly with cutting rings and nuts for the two L22 Male DIN threads (components shown in green). Looking at the 'Component Compatibility Chart' on page 2, one would notice the compatible nuts for this assembly would be 5201L-22 with the compatible cutting rings being 5202-22.

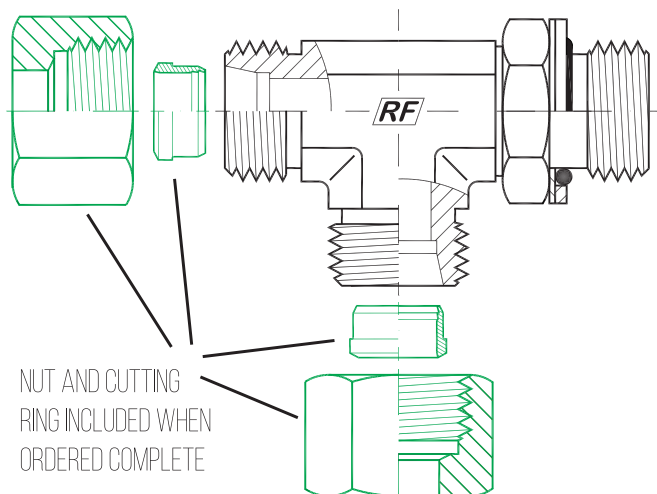

24° DIN (BITE-TYPE) TUBE FITTINGS

STRAIGHT

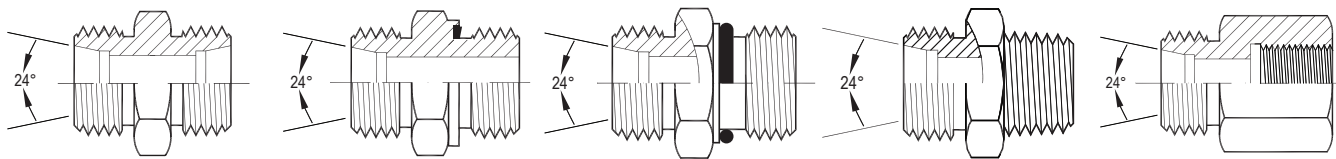

5000 - LL / L / S

5002 - L / S

5006 - L / S

5007 - LL / L / S

5009 - L / S

STRAIGHT SWIVELS

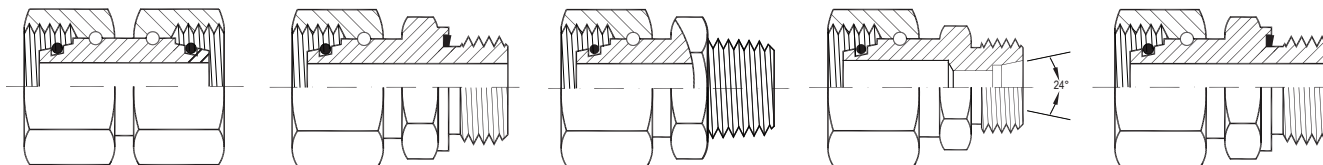

5300 - L / S

5302 - L / S

5307 - L / S

5315 - L / S

5368 - L / S

45° ELBOWS

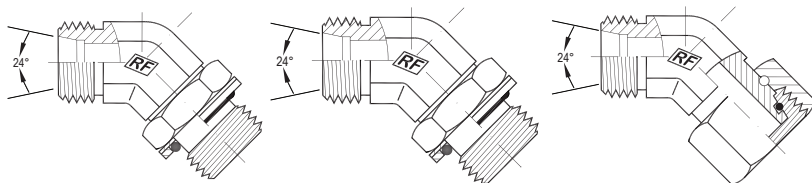

5058 - L / S

5066 - L / S

5362 - L / S

90° ELBOWS

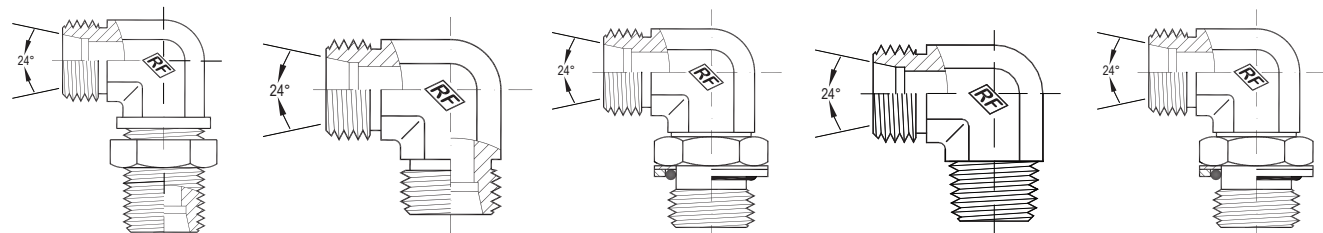

5042 - L / S

5055 - LL / L / S

5059 - L / S

5063 - LL / L

5069 - L / S

TEES & CROSSES

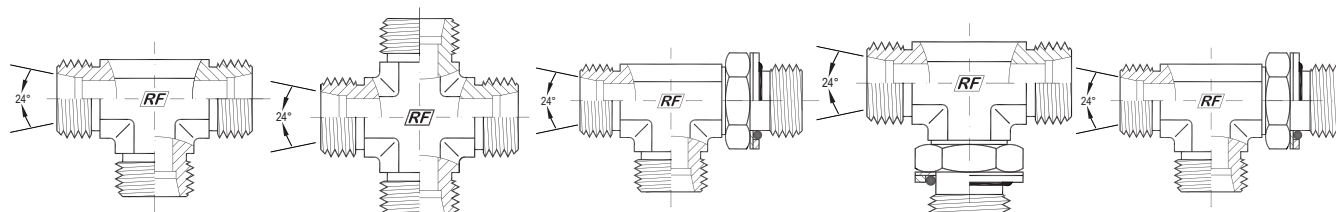

5080 - LL / L / S

5096 - L / S

5158 - L / S

5159 - L / S

5168 - L / S

COMPONENTS

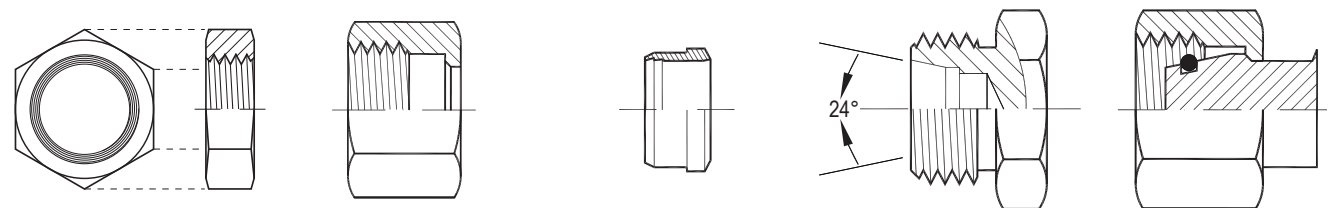

5041 - L / S

5201 - LL / L / S

5202 - LL / L / S

5203 - L / S

5204 - L / S

24° DIN (BITE-TYPE) TUBE FITTINGS

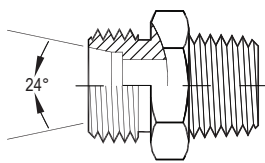

5011-LL/L

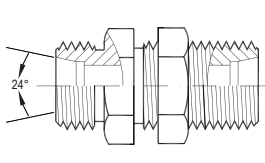

5040-L/S

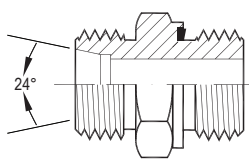

5068-L/S

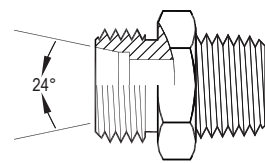

5068LLT-LL

STRAIGHT

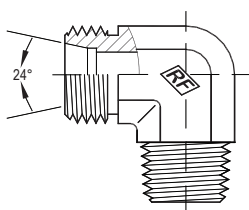

5069LLT-LL

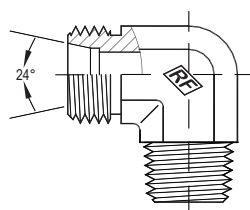

5070-LL/L/S

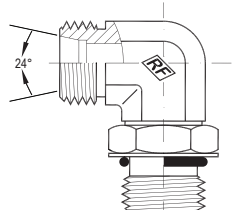

5077-L/S

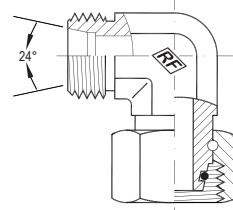

5360-L/S

STRAIGHT
SWIVELS

45° ELBOWS

90° ELBOWS

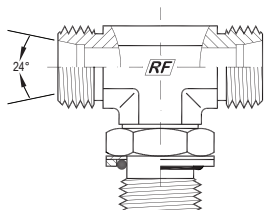

5169-L/S

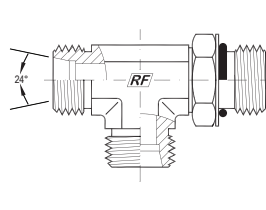

5178-L/S

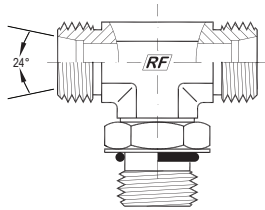

5179-L/S

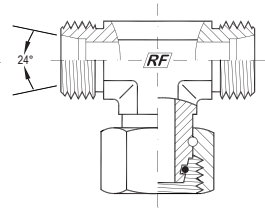

5387-L/S

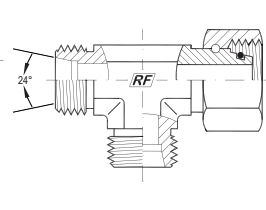

5390-L/S

TEES &
CROSSES

COMPONENTS

Index by series number available on page 19

24° DIN (BITE-TYPE) TUBE FITTINGS

STRAIGHT

5000LL

DIN UNION
(EXTRA LIGHT DUTY)

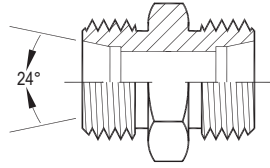

5000LL-04	5000LL-08	5000LL-10
5000LL-06	*Only available complete, see page 5	

5000L

DIN UNION
(LIGHT DUTY)

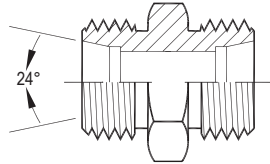

5000L-06	5000L-15	5000L-28
5000L-08	5000L-18	5000L-35
5000L-10	5000L-22	5000L-42
5000L-12		

5000S

DIN UNION
(HEAVY DUTY)

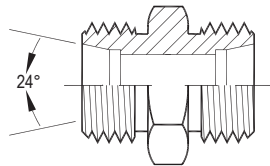

5000S-06	5000S-14	5000S-25
5000S-08	5000S-16	5000S-30
5000S-10	5000S-20	5000S-38
5000S-12		

5002L

DIN (LIGHT DUTY) X
MALE BSPP ES SEAL

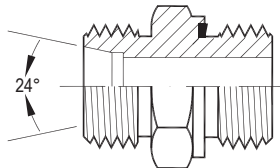

5002L-06-02	5002L-10-08	5002L-18-08
5002L-06-04	5002L-12-04	5002L-18-12
5002L-08-02	5002L-12-06	5002L-22-12
5002L-08-04	5002L-12-08	5002L-28-16
5002L-08-06	5002L-15-06	5002L-35-20
5002L-10-04	5002L-15-08	5002L-42-24
5002L-10-06		

5002S

DIN (HEAVY DUTY) X
MALE BSPP ES SEAL

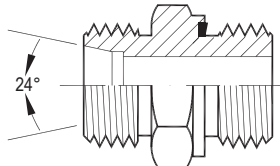

5002S-06-04	5002S-12-06	5002S-20-08
5002S-08-04	5002S-12-08	5002S-20-12
5002S-08-06	5002S-14-08	5002S-25-12
5002S-10-04	5002S-16-06	5002S-25-16
5002S-10-06	5002S-16-08	5002S-30-20
5002S-10-08	5002S-16-12	5002S-38-24
5002S-12-04		

5006L

DIN (LIGHT DUTY) X
MALE SAE ORB

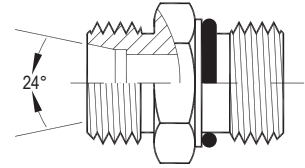

5006L-06-06	5006L-12-08	5006L-22-12
5006L-08-04	5006L-12-10	5006L-28-10
5006L-08-06	5006L-15-08	5006L-28-12
5006L-10-04	5006L-15-10	5006L-28-16
5006L-10-06	5006L-18-08	5006L-35-20
5006L-10-08	5006L-18-10	5006L-42-24
5006L-12-06	5006L-22-10	

5006S

DIN (HEAVY DUTY) X
MALE SAE ORB

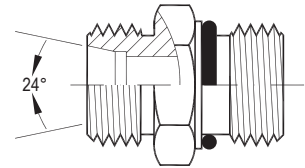

5006S-12-08	5006S-20-08	5006S-25-16
5006S-16-08	5006S-20-10	5006S-30-20
5006S-16-10	5006S-20-12	5006S-38-24

5007LL

DIN (EXTRA LIGHT DUTY) X
MALE NPT

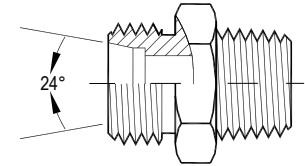

5007LL-04-02	5007LL-08-02	5007LL-10-04
5007LL-06-02	*Only available complete, see page 5	

5007L

DIN (LIGHT DUTY) X
MALE NPT

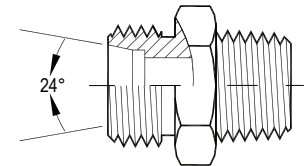

5007L-06-02	5007L-12-04	5007L-22-12
5007L-06-04	5007L-12-06	5007L-28-16
5007L-08-04	5007L-12-08	5007L-35-20
5007L-10-04	5007L-15-08	5007L-42-24
5007L-10-06	5007L-18-08	

5007S

DIN (HEAVY DUTY) X
MALE NPT

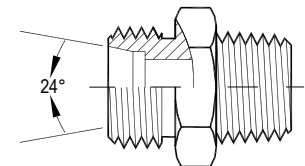

5007S-06-04	5007S-12-06	5007S-20-12
5007S-08-04	5007S-12-08	5007S-25-16
5007S-10-04	5007S-14-08	5007S-30-20
5007S-10-06	5007S-16-08	5007S-38-24
5007S-12-04		

STRAIGHT
SWIVELS

45° ELBOWS

90° ELBOWS

TEES &
CROSSES

COMPONENTS

5009L

DIN (LIGHT DUTY) X FEMALE BSP SOLID

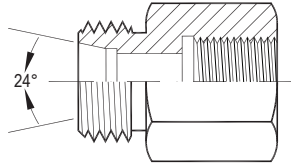

5009L-06-02	5009L-12-06	5009L-22-12
5009L-08-04	5009L-12-08	5009L-28-16
5009L-10-04	5009L-15-08	5009L-35-20
5009L-12-04	5009L-18-08	5009L-42-24

5009S

DIN (HEAVY DUTY) X FEMALE BSP SOLID

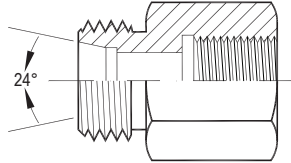

5009S-06-04	5009S-14-08	5009S-25-16
5009S-08-04	5009S-16-08	5009S-30-20
5009S-10-06	5009S-20-12	5009S-38-24
5009S-12-06		

5011LL

DIN (EXTRA LIGHT DUTY) X MALE BSPT

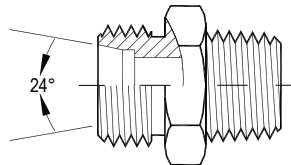

5011LL-04-02	5011LL-08-02	5011LL-10-04
5011LL-06-02	5011LL-08-04	

*Only available complete, see page 5

5011L

DIN (LIGHT DUTY) X MALE BSPT

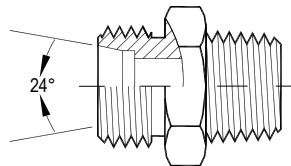

5011L-06-04	5011L-10-04	5011L-12-06
5011L-08-04	5011L-10-06	5011L-12-08
5011L-08-06	5011L-12-04	5011L-15-08

5040L

DIN BULKHEAD UNION (LIGHT DUTY)

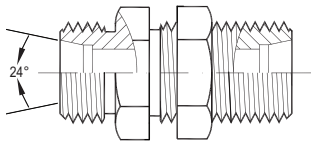

5040L-06	5040L-15	5040L-28
5040L-08	5040L-18	5040L-35
5040L-10	5040L-22	5040L-42
5040L-12		

5040S

DIN BULKHEAD UNION (HEAVY DUTY)

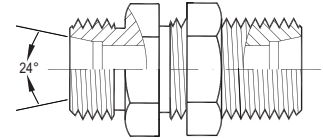

5040S-06	5040S-14	5040S-25
5040S-08	5040S-16	5040S-30
5040S-10	5040S-20	5040S-38
5040S-12		

5068L

DIN (LIGHT DUTY) X MALE METRIC ES SEAL

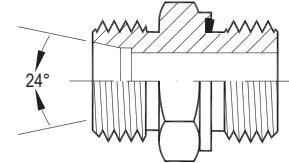

5068L-06-10	5068L-12-18	5068L-18-22
5068L-08-12	5068L-12-22	5068L-22-26
5068L-10-14	5068L-15-18	5068L-28-33
5068L-10-18	5068L-15-22	5068L-35-42
5068L-10-22	5068L-18-18	5068L-42-48
5068L-12-16		

5068S

DIN (HEAVY DUTY) X MALE METRIC ES SEAL

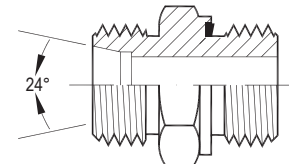

5068S-06-12	5068S-14-20	5068S-25-33
5068S-08-14	5068S-16-22	5068S-30-42
5068S-10-16	5068S-20-27	5068S-38-48
5068S-12-18		

5068LLT

DIN (EXTRA LIGHT DUTY) X MALE METRIC TAPER

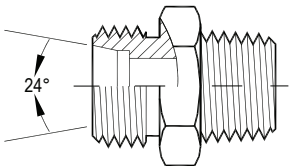

5068LLT-04-6X1	5068LLT-06-10X1	5068LLT-08-10X1
5068LLT-04-8X1		

*Only available complete, see page 5

24° DIN (BITE-TYPE) TUBE FITTINGS

STRAIGHT

5300L

FEMALE DIN SWIVEL UNION
(LIGHT DUTY)

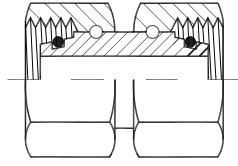

5300L-06	5300L-15	5300L-28
5300L-08	5300L-18	5300L-35
5300L-10	5300L-22	5300L-42
5300L-12		

5307S

FEMALE DIN SWIVEL
(HEAVY DUTY) X MALE NPT

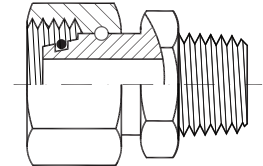

5307S-06-04	5307S-14-08	5307S-25-16
5307S-08-04	5307S-16-08	5307S-30-20
5307S-10-06	5307S-20-12	5307S-38-24
5307S-12-06		

STRAIGHT SWIVELS

5300S

FEMALE DIN SWIVEL UNION
(HEAVY DUTY)

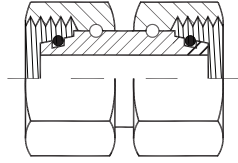

5300S-06	5300S-14	5300S-25
5300S-08	5300S-16	5300S-30
5300S-10	5300S-20	5300S-38
5300S-12		

5315L

FEMALE DIN SWIVEL X
MALE DIN REDUCER
(LIGHT DUTY)

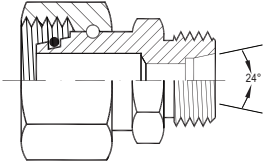

5315L-08-06*	5315L-18-12	5315L-28-22
5315L-10-06	5315L-18-15	5315L-35-12*
5315L-10-08	5315L-22-08*	5315L-35-15*
5315L-12-06	5315L-22-10*	5315L-35-18*
5315L-12-08	5315L-22-12	5315L-35-22
5315L-12-10	5315L-22-15	5315L-35-28
5315L-15-06*	5315L-22-18	5315L-42-12*
5315L-15-08*	5315L-28-08*	5315L-42-15*
5315L-15-10	5315L-28-10*	5315L-42-18*
5315L-15-12	5315L-28-12*	5315L-42-22*
5315L-18-06*	5315L-28-15*	5315L-42-28*
5315L-18-08*	5315L-28-18	5315L-42-35
5315L-18-10*		

*POR - consult your sales representative for price & availability

45° ELBOWS

5302L

FEMALE DIN SWIVEL
(LIGHT DUTY) X
MALE BSPP ES SEAL

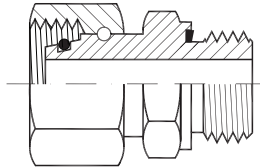

5302L-06-02	5302L-12-06	5302L-28-16
5302L-08-04	5302L-15-08	5302L-35-20
5302L-10-04	5302L-18-08	5302L-42-24
5302L-12-04	5302L-22-12	

90° ELBOWS

5302S

FEMALE DIN SWIVEL
(HEAVY DUTY) X
MALE BSPP ES SEAL

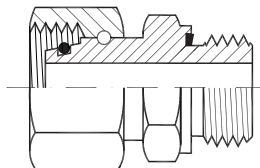

5302S-06-04	5302S-12-08	5302S-25-16
5302S-08-04	5302S-14-08	5302S-30-20
5302S-10-06	5302S-16-08	5302S-38-24
5302S-12-06	5302S-20-12	

TEES & CROSSES

5307L

FEMALE DIN SWIVEL
(LIGHT DUTY) X MALE NPT

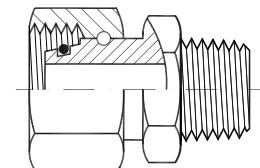

5307L-06-02	5307L-15-08	5307L-28-16
5307L-08-04	5307L-18-08	5307L-35-20
5307L-10-04	5307L-22-12	5307L-42-24
5307L-12-06		

5315S

FEMALE DIN SWIVEL X
MALE DIN REDUCER
(HEAVY DUTY)

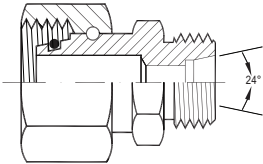

5315S-08-06	5315S-16-10	5315S-25-16*
5315S-10-06	5315S-16-12	5315S-25-20
5315S-10-08	5315S-16-14	5315S-30-12*
5315S-12-06*	5315S-20-08*	5315S-30-14*
5315S-12-08	5315S-20-10*	5315S-30-16*
5315S-12-10	5315S-20-12	5315S-30-20
5315S-14-06*	5315S-20-14*	5315S-30-25
5315S-14-08*	5315S-20-16	5315S-38-12*
5315S-14-10	5315S-25-08*	5315S-38-16*
5315S-14-12	5315S-25-10*	5315S-38-20*
5315S-16-06*	5315S-25-12*	5315S-38-25
5315S-16-08*	5315S-25-14*	5315S-38-30

*POR - consult your sales representative for price & availability

COMPONENTS

5368L

FEMALE DIN SWIVEL
(LIGHT DUTY) X
MALE METRIC ES SEAL

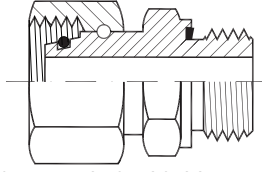

5368L-06-10	5368L-15-18	5368L-28-33
5368L-08-12	5368L-18-22	5368L-35-42
5368L-10-14	5368L-22-26	5368L-42-48
5368L-12-16		

5368S

FEMALE DIN SWIVEL
(HEAVY DUTY) X
MALE METRIC ES SEAL

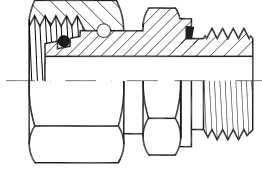

5368S-06-12	5368S-14-20	5368S-25-33
5368S-08-14	5368S-16-22	5368S-30-42
5368S-10-16	5368S-20-27	5368S-38-48
5368S-12-18		

STRAIGHT

STRAIGHT
SWIVELS

45° ELBOWS

90° ELBOWS

TEES &
CROSSES

COMPONENTS

Dimensions and specs available at www.adaptall.com

24° DIN (BITE-TYPE) TUBE FITTINGS

STRAIGHT

5058L

45° DIN (LIGHT DUTY) X
MALE BSPP ADJ. ELBOW

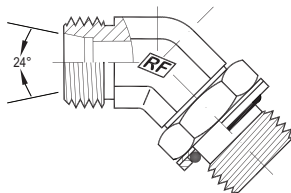

5058L-06-02	5058L-12-06	5058L-22-12
5058L-08-04	5058L-15-08	5058L-28-16
5058L-10-04	5058L-18-08	

5362L

45° MALE DIN X
FEMALE DIN SWIVEL ELBOW
(LIGHT DUTY)

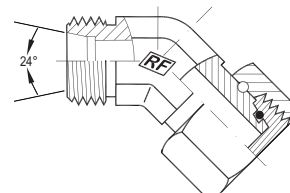

5362L-06	5362L-15	5362L-28
5362L-08	5362L-18	5362L-35
5362L-10	5362L-22	5362L-42
5362L-12		

STRAIGHT
SWIVELS

5058S

45° DIN (HEAVY DUTY) X
MALE BSPP ADJ. ELBOW

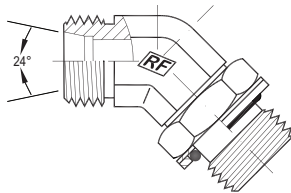

5058S-06-04	5058S-12-06	5058S-20-12
5058S-08-04	5058S-14-08	5058S-25-16
5058S-10-06	5058S-16-08	

5362S

45° MALE DIN X
FEMALE DIN SWIVEL ELBOW
(HEAVY DUTY)

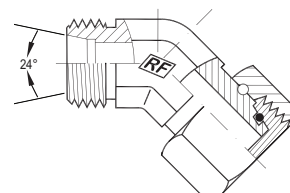

5362S-06	5362S-14	5362S-25
5362S-08	5362S-16	5362S-30
5362S-10	5362S-20	5362S-38
5362S-12		

45° ELBOWS

5066L

45° DIN (LIGHT DUTY) X
MALE METRIC ADJ. ELBOW

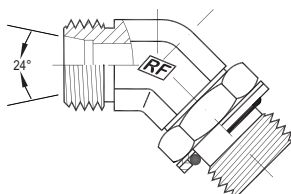

5066L-06-10	5066L-12-16	5066L-22-27
5066L-08-12	5066L-15-18	5066L-28-33
5066L-10-14	5066L-18-22	

90° ELBOWS

5066S

45° DIN (HEAVY DUTY) X
MALE METRIC ADJ. ELBOW

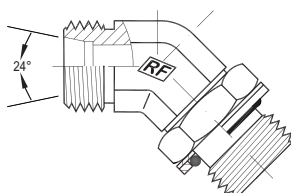

5066S-06-12	5066S-12-18	5066S-20-27
5066S-08-14	5066S-14-20	5066S-25-33
5066S-10-16	5066S-16-22	

TEES &
CROSSES

COMPONENTS

STRAIGHT

STRAIGHT SWIVELS

45° ELBOWS

90° ELBOWS

TEES & CROSSES

COMPONENTS

5042L

90° DIN BULKHEAD UNION ELBOW (LIGHT DUTY)

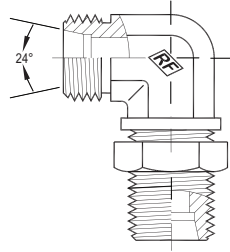

5042L-06	5042L-15	5042L-28
5042L-08	5042L-18	5042L-35
5042L-10	5042L-22	5042L-42
5042L-12		

5042S

90° DIN BULKHEAD UNION ELBOW (HEAVY DUTY)

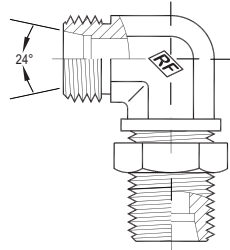

5042S-06	5042S-14	5042S-25
5042S-08	5042S-16	5042S-30
5042S-10	5042S-20	5042S-38
5042S-12		

5055LL

90° DIN UNION ELBOW (EXTRA LIGHT DUTY)

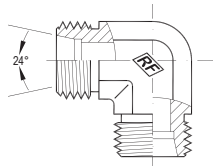

5055LL-04	5055LL-08	5055LL-10
5055LL-06		

**Only available complete, see page 5*

5055L

90° DIN UNION ELBOW (LIGHT DUTY)

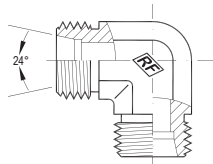

5055L-06	5055L-15	5055L-28
5055L-08	5055L-18	5055L-35
5055L-10	5055L-22	5055L-42
5055L-12		

5055S

90° DIN UNION ELBOW (HEAVY DUTY)

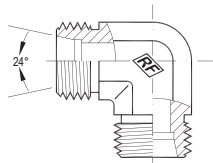

5055S-06	5055S-14	5055S-25
5055S-08	5055S-16	5055S-30
5055S-10	5055S-20	5055S-38
5055S-12		

5059L

90° DIN (LIGHT DUTY) X MALE BSPP ADJ. ELBOW

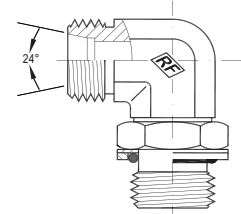

5059L-06-02	5059L-15-08	5059L-28-16
5059L-08-04	5059L-18-08	5059L-35-20
5059L-10-04	5059L-22-12	5059L-42-24
5059L-12-06		

5059S

90° DIN (HEAVY DUTY) X MALE BSPP ADJ. ELBOW

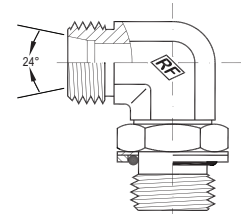

5059S-06-04	5059S-14-08	5059S-25-16
5059S-08-04	5059S-16-08	5059S-30-20
5059S-10-06	5059S-20-12	5059S-38-24
5059S-12-06		

5063LL

90° DIN (EXTRA LIGHT DUTY) X MALE BSPT ELBOW

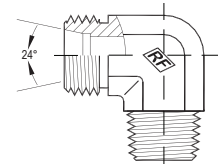

5063LL-04-02	5063LL-08-02	5063LL-10-04
5063LL-06-02		

**Only available complete, see page 5*

5063L

90° DIN (LIGHT DUTY) X MALE BSPT ELBOW

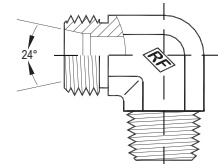

5063L-06-02	5063L-10-04	5063L-12-06
5063L-06-04	5063L-10-06	5063L-15-08
5063L-08-02	5063L-12-04	5063L-18-08
5063L-08-04		

24° DIN (BITE-TYPE) TUBE FITTINGS

STRAIGHT

5069L

90° DIN (LIGHT DUTY) X
MALE METRIC ADJ. ELBOW

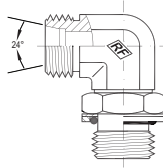

5069L-06-10	5069L-15-18	5069L-28-33
5069L-08-12	5069L-18-22	5069L-35-42
5069L-10-14	5069L-22-27	5069L-42-48
5069L-12-16		

5070S

90° DIN (HEAVY DUTY) X
MALE NPT ELBOW

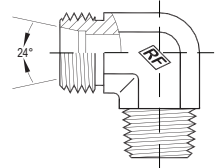

5070S-06-04	5070S-12-06	5070S-20-12
5070S-08-04	5070S-14-08	5070S-25-16
5070S-10-06	5070S-16-08	5070S-30-20

STRAIGHT SWIVELS

5069S

90° DIN (HEAVY DUTY) X
MALE METRIC ADJ. ELBOW

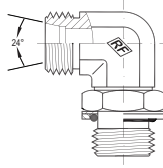

5069S-06-12	5069S-14-20	5069S-25-33
5069S-08-14	5069S-16-22	5069S-30-42
5069S-10-16	5069S-20-27	5069S-38-48
5069S-12-18		

5077L

90° DIN (LIGHT DUTY) X
MALE SAE ORB ADJ. ELBOW

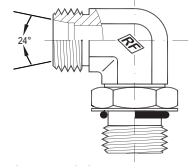

5077L-06-04	5077L-15-10	5077L-28-16
5077L-08-04	5077L-18-10	5077L-35-20
5077L-10-06	5077L-22-12	5077L-42-24
5077L-12-08		

45° ELBOWS

5069LLT

90° DIN (EXTRA LIGHT DUTY) X
MALE METRIC TAPER ELBOW

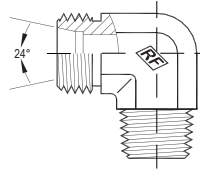

5069LLT-06-10X1	5069LLT-08-10X1
-----------------	-----------------

*Only available complete, see page 5

5077S

90° DIN (HEAVY DUTY) X
MALE SAE ORB ADJ. ELBOW

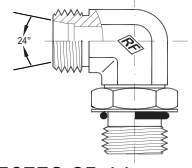

5077S-06-04	5077S-14-10	5077S-25-16
5077S-08-06	5077S-16-10	5077S-30-20
5077S-10-06	5077S-20-12	5077S-38-24
5077S-12-08		

90° ELBOWS

5070LL

90° DIN (EXTRA LIGHT DUTY) X
MALE NPT ELBOW

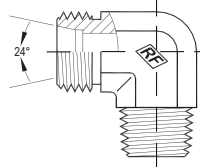

5070LL-04-02	5070LL-08-02	5070LL-10-04
5070LL-06-02	*Only available complete, see page 5	

5360L

90° MALE DIN X
FEMALE DIN SWIVEL ELBOW
(LIGHT DUTY)

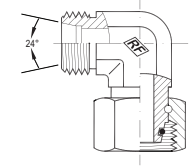

5360L-06	5360L-15	5360L-28
5360L-08	5360L-18	5360L-35
5360L-10	5360L-22	5360L-42
5360L-12		

TEES & CROSSES

5070L

90° DIN (LIGHT DUTY) X
MALE NPT ELBOW

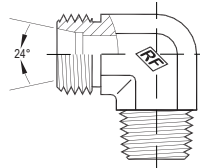

5070L-06-02	5070L-12-06	5070L-22-12
5070L-08-04	5070L-15-08	5070L-28-16
5070L-10-04	5070L-18-08	5070L-35-20
5070L-12-04		

5360S

90° MALE DIN X
FEMALE DIN SWIVEL ELBOW
(HEAVY DUTY)

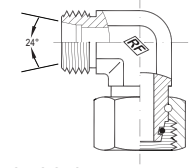

5360S-06	5360S-14	5360S-25
5360S-08	5360S-16	5360S-30
5360S-10	5360S-20	5360S-38
5360S-12		

COMPONENTS

STRAIGHT

5080LL

DIN UNION TEE
(EXTRA LIGHT DUTY)

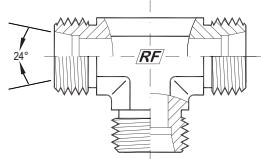

5080LL-04	5080LL-08	5080LL-10
5080LL-06	*Only available complete, see page 5	

5080L

DIN UNION TEE
(LIGHT DUTY)

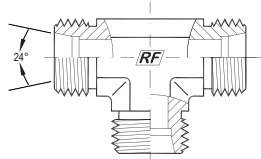

5080L-06	5080L-15	5080L-28
5080L-08	5080L-18	5080L-35
5080L-10	5080L-22	5080L-42
5080L-12		

5080S

DIN UNION TEE
(HEAVY DUTY)

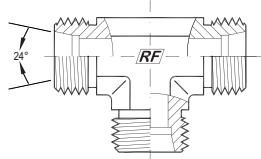

5080S-06	5080S-14	5080S-25
5080S-08	5080S-16	5080S-30
5080S-10	5080S-20	5080S-38
5080S-12		

5096L

DIN UNION CROSS
(LIGHT DUTY)

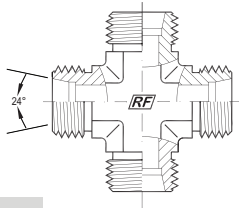

5096L-06	5096L-10
5096L-08	5096L-12

5096S

DIN UNION CROSS
(HEAVY DUTY)

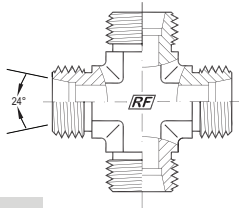

5096S-06	5096S-10
5096S-08	5096S-12

5158L

DIN (LIGHT DUTY) X
MALE BSPP ADJ. RUN TEE

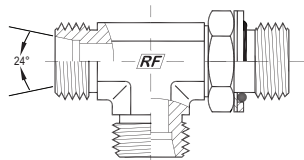

5158L-06-06-02	5158L-15-15-08	5158L-28-28-16
5158L-08-08-04	5158L-18-18-08	5158L-35-35-20
5158L-10-10-04	5158L-22-22-12	5158L-42-42-24
5158L-12-12-06		

5158S

DIN (HEAVY DUTY) X
MALE BSPP ADJ. RUN TEE

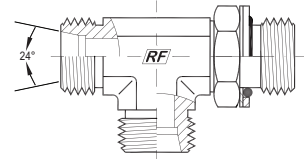

5158S-06-06-04	5158S-14-14-08	5158S-25-25-16
5158S-08-08-04	5158S-16-16-08	5158S-30-30-20
5158S-10-10-06	5158S-20-20-12	5158S-38-38-24
5158S-12-12-06		

5159L

DIN (LIGHT DUTY) X
MALE BSPP ADJ. BRANCH TEE

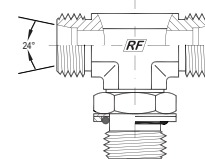

5159L-06-06-02	5159L-15-15-08	5159L-28-28-16
5159L-08-08-04	5159L-18-18-08	5159L-35-35-20
5159L-10-10-04	5159L-22-22-12	5159L-42-42-24
5159L-12-12-06		

5159S

DIN (HEAVY DUTY) X
MALE BSPP ADJ. BRANCH TEE

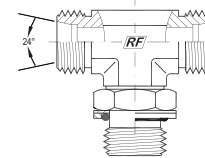

5159S-06-06-04	5159S-14-14-08	5159S-25-25-16
5159S-08-08-04	5159S-16-16-08	5159S-30-30-20
5159S-10-10-06	5159S-20-20-12	5159S-38-38-24
5159S-12-12-06		

5168L

DIN (LIGHT DUTY) X
MALE METRIC ADJ. RUN TEE

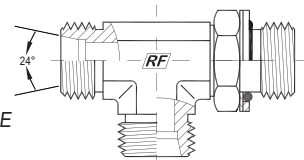

5168L-06-06-10	5168L-15-15-18	5168L-28-28-33
5168L-08-08-12	5168L-18-18-22	5168L-35-35-42
5168L-10-10-14	5168L-22-22-27	5168L-42-42-48
5168L-12-12-16		

5168S

DIN (HEAVY DUTY) X
MALE METRIC ADJ. RUN TEE

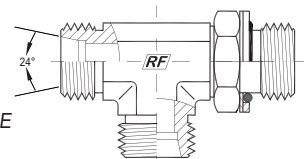

5168S-06-06-12	5168S-14-14-20	5168S-25-25-33
5168S-08-08-14	5168S-16-16-22	5168S-30-30-42
5168S-10-10-16	5168S-20-20-27	5168S-38-38-48
5168S-12-12-18		

STRAIGHT
SWIVELS

45° ELBOWS

90° ELBOWS

TEES &
CROSSES

COMPONENTS

Dimensions and specs available at www.adaptall.com

24° DIN (BITE-TYPE) TUBE FITTINGS

STRAIGHT

5169L

DIN (LIGHT DUTY) X
MALE METRIC ADJ. BRANCH TEE

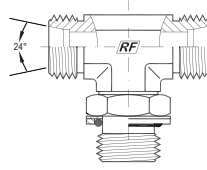

5169L-06-06-10	5169L-15-15-18	5169L-28-28-33
5169L-08-08-12	5169L-18-18-22	5169L-35-35-42
5169L-10-10-14	5169L-22-22-27	5169L-42-42-48
5169L-12-12-16		

5179S

DIN (HEAVY DUTY) X
MALE SAE ORB ADJ. BRANCH TEE

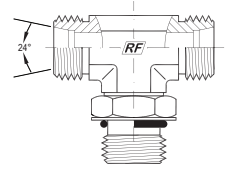

5179S-06-06-04	5179S-14-14-10	5179S-25-25-16
5179S-08-08-06	5179S-16-16-10	5179S-30-30-20
5179S-10-10-06	5179S-20-20-12	5179S-38-38-24
5179S-12-12-08		

STRAIGHT SWIVELS

5169S

DIN (HEAVY DUTY) X
MALE METRIC ADJ. BRANCH TEE

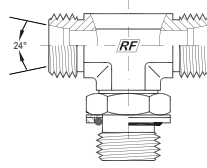

5169S-06-06-12	5169S-14-14-20	5169S-25-25-33
5169S-08-08-14	5169S-16-16-22	5169S-30-30-42
5169S-10-10-16	5169S-20-20-27	5169S-38-38-48
5169S-12-12-18		

5387L

FEMALE DIN SWIVEL BRANCH
TEE (LIGHT DUTY)

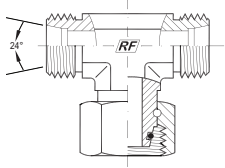

5387L-06	5387L-15	5387L-28
5387L-08	5387L-18	5387L-35
5387L-10	5387L-22	5387L-42
5387L-12		

45° ELBOWS

5178L

DIN (LIGHT DUTY) X
MALE SAE ORB ADJ. RUN TEE

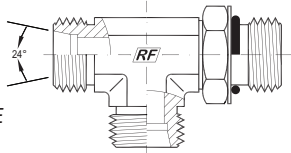

5178L-06-06-04	5178L-15-15-10	5178L-28-28-16
5178L-08-08-04	5178L-18-18-10	5178L-35-35-20
5178L-10-10-06	5178L-22-22-12	5178L-42-42-24
5178L-12-12-08		

5387S

FEMALE DIN SWIVEL BRANCH
TEE (HEAVY DUTY)

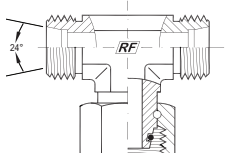

5387S-06	5387S-14	5387S-25
5387S-08	5387S-16	5387S-30
5387S-10	5387S-20	5387S-38
5387S-12		

90° ELBOWS

5178S

DIN (HEAVY DUTY) X
MALE SAE ORB ADJ. RUN TEE

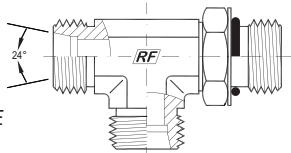

5178S-06-06-04	5178S-14-14-10	5178S-25-25-16
5178S-08-08-06	5178S-16-16-10	5178S-30-30-20
5178S-10-10-06	5178S-20-20-12	5178S-38-38-24
5178S-12-12-08		

5390L

FEMALE DIN SWIVEL RUN TEE
(LIGHT DUTY)

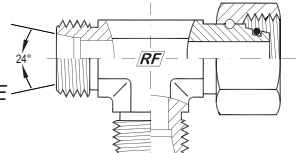

5390L-06	5390L-15	5390L-28
5390L-08	5390L-18	5390L-35
5390L-10	5390L-22	5390L-42
5390L-12		

TEES & CROSSES

5179L

DIN (LIGHT DUTY) X
MALE SAE ORB ADJ. BRANCH TEE

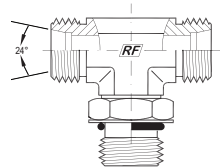

5179L-06-06-04	5179L-15-15-10	5179L-28-28-16
5179L-08-08-04	5179L-18-18-10	5179L-35-35-20
5179L-10-10-06	5179L-18-18-12	5179L-42-42-24
5179L-12-12-08	5179L-22-22-12	

5390S

FEMALE DIN SWIVEL RUN TEE
(HEAVY DUTY)

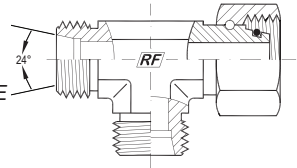

5390S-06	5390S-14	5390S-25
5390S-08	5390S-16	5390S-30
5390S-10	5390S-20	5390S-38
5390S-12		

COMPONENTS

5041

METRIC BULKHEAD NUT
(FOR USE WITH LIGHT &
HEAVY DUTY)

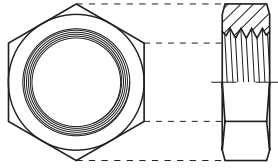

5041-12	5041-18	5041-24
5041-14	5041-20	5041-26
5041-16	5041-22	

5201LL

DIN TUBE NUT
(EXTRA LIGHT DUTY)

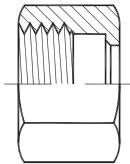

5201LL-04	5201LL-08	5201LL-12
5201LL-06	5201LL-10	

5201L

DIN TUBE NUT
(LIGHT DUTY)

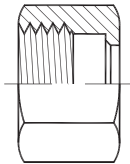

5201L-06	5201L-15	5201L-28
5201L-08	5201L-18	5201L-35
5201L-10	5201L-22	5201L-42
5201L-12		

5201S

DIN TUBE NUT
(HEAVY DUTY)

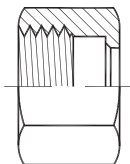

5201S-06	5201S-14	5201S-25
5201S-08	5201S-16	5201S-30
5201S-10	5201S-20	5201S-38
5201S-12		

5202LL

DIN CUTTING RING
(EXTRA LIGHT DUTY)

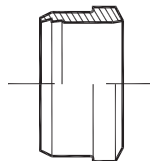

5202LL-04	5202LL-08	5202LL-12
5202LL-06	5202LL-10	

5202

DIN CUTTING RING
(FOR USE WITH LIGHT &
HEAVY DUTY)

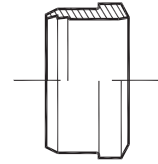

5202-06	5202-16	5202-28
5202-08	5202-18	5202-30
5202-10	5202-20	5202-35
5202-12	5202-22	5202-38
5202-14	5202-25	5202-42
5202-15		

5203L

DIN TUBE PLUG
(LIGHT DUTY)

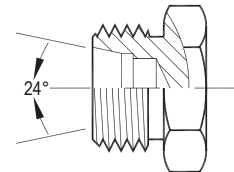

5203L-06	5203L-15	5203L-28
5203L-08	5203L-18	5203L-35
5203L-10	5203L-22	5203L-42
5203L-12		

5203S

DIN TUBE PLUG
(HEAVY DUTY)

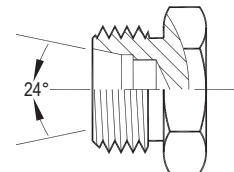

5203S-06	5203S-14	5203S-25
5203S-08	5203S-16	5203S-30
5203S-10	5203S-20	5203S-38
5203S-12		

5204L

DIN SOFT SEAL TUBE CAP
(LIGHT DUTY)

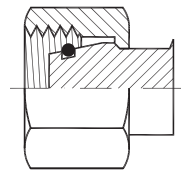

5204L-06	5204L-15	5204L-28
5204L-08	5204L-18	5204L-35
5204L-10	5204L-22	5204L-42
5204L-12		

5204S

DIN SOFT SEAL TUBE CAP
(HEAVY DUTY)

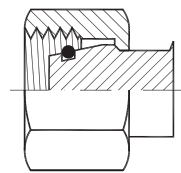

5204S-06	5204S-14	5204S-25
5204S-08	5204S-16	5204S-30
5204S-10	5204S-20	5204S-38
5204S-12		

STRAIGHT

STRAIGHT
SWIVELS

45° ELBOWS

90° ELBOWS

TEES &
CROSSES

COMPONENTS

24° DIN (BITE-TYPE) TUBE FITTINGS

SUPERIOR PRODUCT FROM ADAPTALL

Adaptall's DIN tube fitting line achieves superior corrosion resistance, allowing 350+ hours to white rust and 700+ hours to red rust. This far exceeds the SAE requirements.

Somewhat unique to Adaptall is the ability to source tube fittings & components either separately or as a complete assembly. What is also unique to Adaptall is that there are no additional or hidden assembly fees for purchasing full tube fitting assemblies versus individual fittings or components.

If you do not require cutting rings and nuts, simply order the fitting. If you require cutting rings and nuts to go with your fitting, order as complete; pricing of fittings and components will always be consistent regardless if assembled or not.

Adaptall strives to provide superior customer service and technical support to match the high quality product offering. Our expertise and experience with International threads and fittings makes us the ideal choice for your tube fitting needs.

Custom fitting design and manufacturing is also available from Adaptall. Fully 'Buy America' compliant, we can make fittings with any thread combination in steel, stainless steel, brass, aluminum, copper and more.

COMPACT ELBOW AND TEE CONNECTIONS

Unique to Adaptall's tube fitting line is the availability of elbows and tees that complete your connection with one fitting instead of two, in instances where the tube connection must be converted to a port application. Most competitors only offer a two fitting solution for DIN elbows and tees going into port, compromising space and increasing your costs.

For example, when converting from DIN tube connection to BSPP port on a 45° elbow, one would normally be forced to incorporate two fittings; a 45° DIN x DIN elbow + DIN x Male BSPP (sealed) nipple. However, Adaptall provides a unique one-piece solution as shown below. Adaptall still provides a two-piece solution if that is preferred.

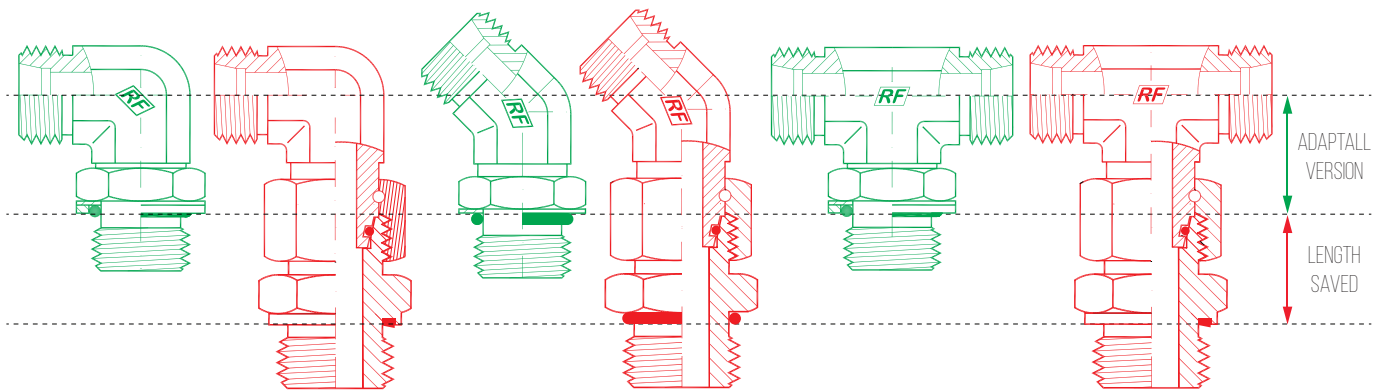

WARRANTY

Adaptall warrants its products to be free of defects in material and workmanship. No warranty of merchantability or other warranty, express or implied, is made.

Liability for and the exclusive remedy for defective materials or workmanship is limited to replacement or repair of defective products returned within 60 days after receipt. No allowance will be made for repairs performed by the purchaser or on buyers order. Adaptall is not liable for consequential or other damages or any expense incurred through the use of its products.

All design and dimensional data are subject to change without notice, including materials, specifications, and standards used. Working pressures, torque settings, corrosion resistance and other technical information have been prepared from data and sources considered to be reliable. However, no responsibility can be assumed for the accuracy of this information under varied field conditions and should be considered as a recommendation only and not a guarantee.

TERMS & CONDITIONS

- Prices subject to change without prior notice
- F.O.B. our plant
- No returns without prior written consent from Adaptall
- All taxes and government surcharges are extra where applicable
- All sales to U.S customers are payable in U.S funds
- Minimum billing: \$25.00 plus taxes

24° DIN (BITE-TYPE) TUBE FITTINGS

SERIES	EXTRA LIGHT DUTY (LL)	LIGHT DUTY (L)	HEAVY DUTY (S)	DESCRIPTION	PAGE #
5000	✓	✓	✓	DIN union	8
5002	•	✓	✓	DIN x male BSPP ES seal	8
5006	•	✓	✓	DIN x male SAE ORB	8
5007	✓	✓	✓	DIN x male NPT	8
5009	•	✓	✓	DIN x female BSP solid	9
5011	✓	✓	•	DIN x male BSPT	9
5040	•	✓	✓	DIN bulkhead union	9
5041	•	✓	✓	Metric bulkhead nut	17
5042	•	✓	✓	90° DIN bulkhead union elbow	13
5055	✓	✓	✓	90° DIN union elbow	13
5058	•	✓	✓	45° DIN x male BSPP adjustable elbow	12
5059	•	✓	✓	90° DIN x male BSPP adjustable elbow	13
5063	✓	✓	•	90° DIN x male BSPT elbow	13
5066	•	✓	✓	45° DIN x male Metric adjustable elbow	12
5068	•	✓	✓	DIN x male Metric ES seal	9
5068LLT	✓	•	•	DIN x male Metric taper	9
5069	•	✓	✓	90° DIN x male Metric adjustable elbow	14
5069LLT	✓	•	•	90° DIN x male Metric taper elbow	14
5070	✓	✓	✓	90° DIN x male NPT elbow	14
5077	•	✓	✓	90° DIN x male SAE ORB adjustable elbow	14
5080	✓	✓	✓	DIN union tee	15
5096	•	✓	✓	DIN union cross	15
5158	•	✓	✓	DIN x male BSPP adjustable run tee	15
5159	•	✓	✓	DIN x male BSPP adjustable branch tee	15
5168	•	✓	✓	DIN x male Metric adjustable run tee	15
5169	•	✓	✓	DIN x male Metric adjustable branch tee	16
5178	•	✓	✓	DIN x male SAE ORB adjustable run tee	16
5179	•	✓	✓	DIN x male SAE ORB adjustable branch tee	16
5201	✓	✓	✓	DIN tube nut	17
5202	✓	✓	✓	DIN cutting ring	17
5203	•	✓	✓	DIN tube plug	17
5204	•	✓	✓	DIN soft seal tube cap	17
5300	•	✓	✓	Female DIN swivel union	10
5302	•	✓	✓	Female DIN swivel x male BSPP ES seal	10
5307	•	✓	✓	Female DIN swivel x male NPT	10
5315	•	✓	✓	Female DIN swivel x male DIN reducer	10
5360	•	✓	✓	90° male DIN x female DIN swivel elbow	14
5362	•	✓	✓	45° male DIN x female DIN swivel elbow	12
5368	•	✓	✓	Female DIN swivel x male Metric ES seal	11
5387	•	✓	✓	Female DIN swivel branch tee	16
5390	•	✓	✓	Female DIN swivel run tee	16

P. (800) 463-8134
F. (800) 994-5699

SALES@ADAPTALL.COM
WWW.ADAPTALL.COM

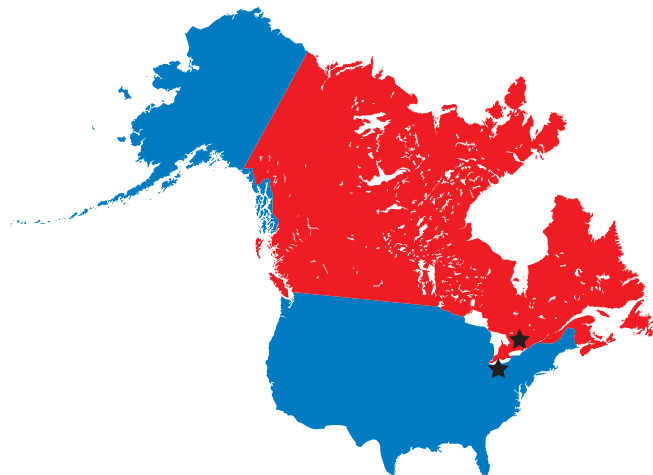

9047 DUTTON DRIVE
TWINSBURG, OH
44087



150 BRUNEL ROAD
MISSISSAUGA, ON
L4Z 1T5



ISO 9001
REGISTERED

adaptall is a registered trademark. The use of the trademark is not permitted without the prior written consent of Adaptall Inc. Reproduction of this literature in whole or in part is not permitted without the prior written consent of Adaptall Inc.

© 2015 Adaptall Inc. PRINTED IN CANADA